



MODEL NO. : TS028HAACB06-00
 ISSUED DATE: 2007-12-25
 VERSION : Ver 1.1

- Preliminary Product Specification
- Final Product Specification

Customer : _____

Approved by	Notes

SHANGHAI TIANMA Confirmed :

prepared by	Checked by	Approved by
徐昀	刘庆全	刘庆全

This technical specification is subjected to change without notice



Table of Contents

NO.	Item	Page
	Cover Sheet	1
	Table of Contents	2
	Record of Revision	3
1	General Specifications	4
2	Input / Output Terminals	5
3	Absolute Maximum Ratings	7
4	Electrical Characteristics	8
5	Interface timing	10
6	Optical Characteristics	15
7	Environmental / Reliability Tests	19
8	Mechanical Drawing	20
9	Packing Drawing	21
10	Precautions for Use of LCD Modules	22



1 GENERAL SPECIFICATIONS

Feature		Spec
Display Spec.	Size	2.83"
	Resolution	240(RGB) X 320
	Interface	CPU
	Color Depth	16bit
	Technology type	a-si
	Pixel pitch (mm)	0.18 x 0.18
	Display colors	262k
	Pixel Configuration	R.G.B. Vertical Stripe
	Display Mode	TM with Normally White
	Surface Treatment	HC, 3H
Gray Scale Inversion Direction	12 o'clock	
Mechanical Characteristics	LCM (W x H x D) (mm)	50.0x69.2x4.2
	Active Area(mm)	43.2 x 57.6
	With /Without TSP	WITH TSP
	Weight (gram)	TBD.
	LED Numbers	4 LEDs parallel
	Driver IC	ILI 9325

Note 1: Requirements on Environmental Protection: RoHS



2 INPUT/OUTPUT TERMINALS

2.1 TFT LCD Panel

No	Symbol	I/O	Description	Comment
1	DB0	I	Data input	
2	DB1	I	Data input	
3	DB2	I	Data input	
4	DB3	I	Data input	
5	GND	P	Ground	
6	VCC	P	Power Supply of Digital Circuit	
7	/CS	I	A chip select signal	
8	RS	I	A register select signal	
9	/WR	I	A write strobe signal and activates when the signal is low	
10	/RD	I	A read strobe signal and activates when the signal is low	
11	NC	-	Not Connect	
12	X+	I	Touch Panel X(Right Side)	
13	Y+	I	Touch Panel Y(Down Side)	
14	X-	I	Touch Panel X(Left Side)	
15	Y-	I	Touch Panel Y(Up Side)	
16	LEDA	I	LED anode	
17	LEDK1	I	LED cathode	
18	LEDK2	I	LED cathode	
19	LEDK3	I	LED cathode	
20	LEDK4	I	LED cathode	
21	NC	-	Not Connect	
22	DB4	I	Data input	
23	DB8	I	Data input	
24	DB9	I	Data input	
25	DB10	I	Data input	
26	DB11	I	Data input	
27	DB12	I	Data input	
28	DB13	I	Data input	
29	DB14	I	Data input	
30	DB15	I	Data input	
31	/RESET	I	A RESET signal	
32	VCI	P	Power Supply of Analog Circuit	



33	VCC	P	Power Supply of Digital Circuit	
34	GND	P	Ground	
35	DB5	I	Data input	
36	DB6	I	Data input	
37	DB7	I	Data input	

Note 2-1: The figure below shows the connection of backlight LED.

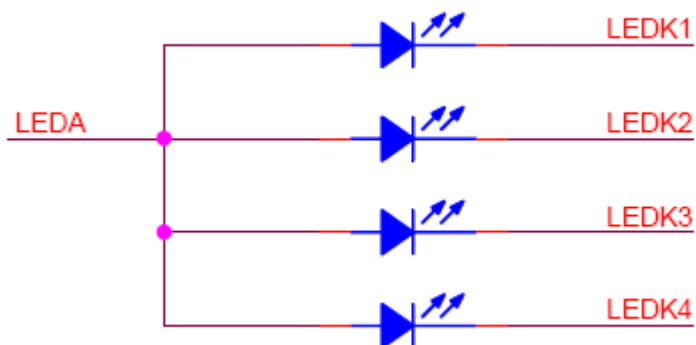

**3. ABSOLUTE MAXIMUM RATINGS**

Ta = 25°C

Item	Symbol	MIN	MAX	Unit	Remark
Supply Voltage	VCC	-0.3	4.6	V	
Analog Supply Voltage	VCI	-0.3	4.6	V	
Input Signal Voltage	/CS,RS,/WR,/RD, /RESET, DB[0 :15]	-0.3	VCC+0.3	V	
Back Light Forward Current	ILED		25	mA	One LED
Operating Temperature	TOPR	-20	60	°C	
Storage Temperature	TSTG	-30	70	°C	



4 ELECTRICAL CHARACTERISTICS

4.1. Driving TFT LCD Panel

GND=0V, Ta=25°C

Item	Symbol	MIN	TYP	MAX	Unit	Remark
Logic Supply Voltage	VCC	2.5	2.8	3.3	V	
Analog Supply Voltage	VCI	2.5	2.8	3.3	V	
Input Signal Voltage	Low Level	V_{IL}	-0.3		0.2*VCC	V
	High Level	V_{IH}	0.8*VCC		VCC	V
(Panel+LSI) Power Consumption	Black Mode (60Hz)		TBD			mW
	8 color Mode		TBD			mW
	Sleeping Mode		TBD			mW

4.2 Driving Backlight Ta=25°C

Item	Symbol	MIN	TYP	MAX	Unit	Remark
Forward Current	I_F	--	20	25	mA	
Forward Current Voltage	V_F	---	3.2	---	V	
Backlight Power Consumption	W_{BL}	--	256	--	mW	

Forward Current Derating Curve

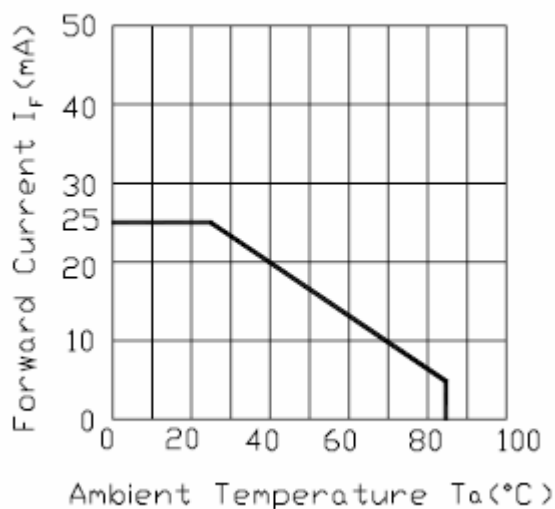



4.3 Block Diagram

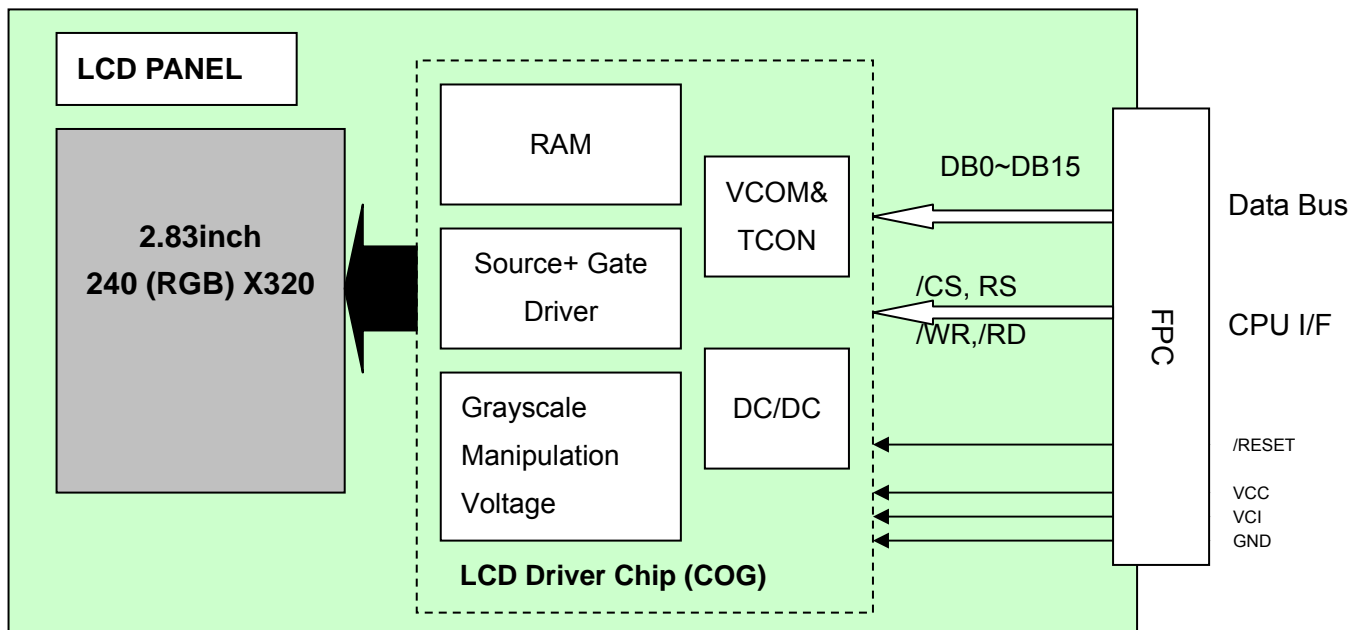



5. INTERFACE TIMING

5.1 Timing Parameter

Item	Symbol	Unit	Min	Typ	Max
Write bus cycle time	t_{CYCW}	ns	100	-	-
Write low-level pulse width	PW_{LW}	ns	50	-	500
Write high-level pulse width	PW_{HW}	ns	50	-	-
Write rise / fall time	t_{Wr} / t_{Wf}	ns	-	-	25
Write Setup time (RS to /CS, /WR)	t_{AS}	ns	10	-	-
Address hold time	t_{AH}	ns	5	-	-
Write data set up time	t_{DSW}	ns	10	-	-
Write data hold time	t_H	ns	15	-	-

Table 5.1 timing parameter

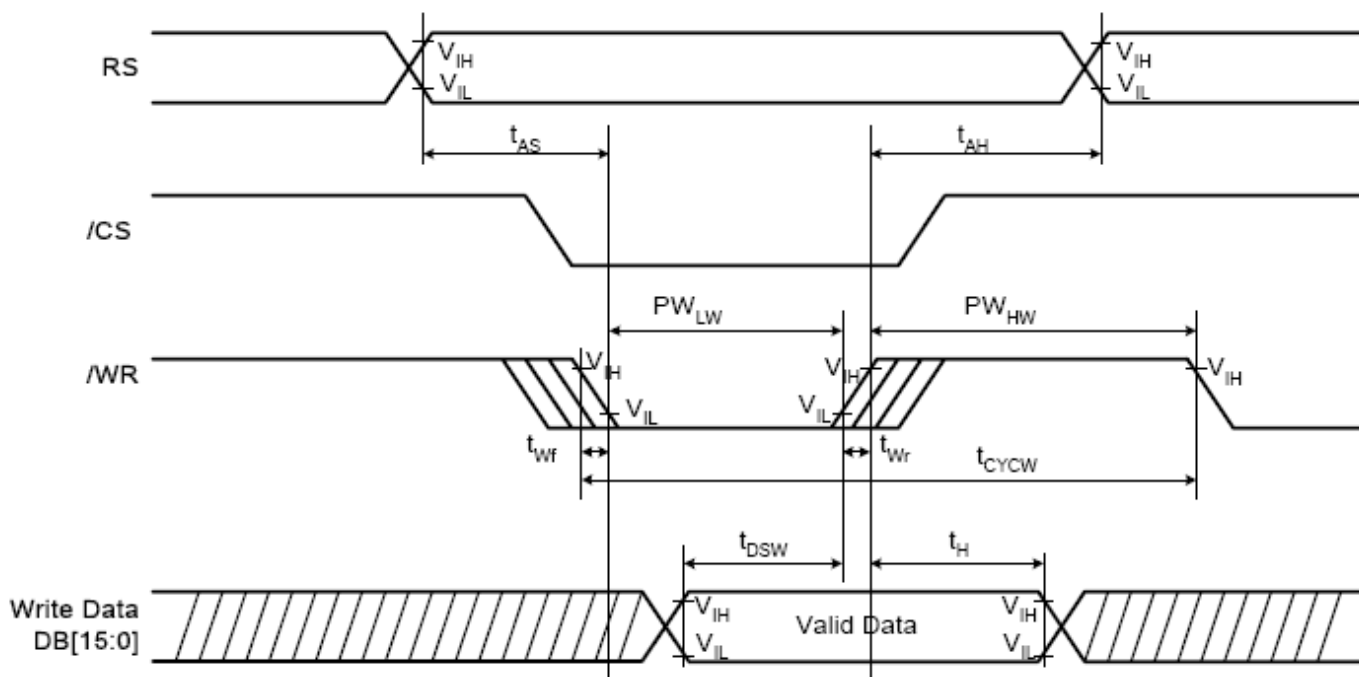

Figure 5.1 i80 System Bus Timing



5.2 Register write timing in I80 series system

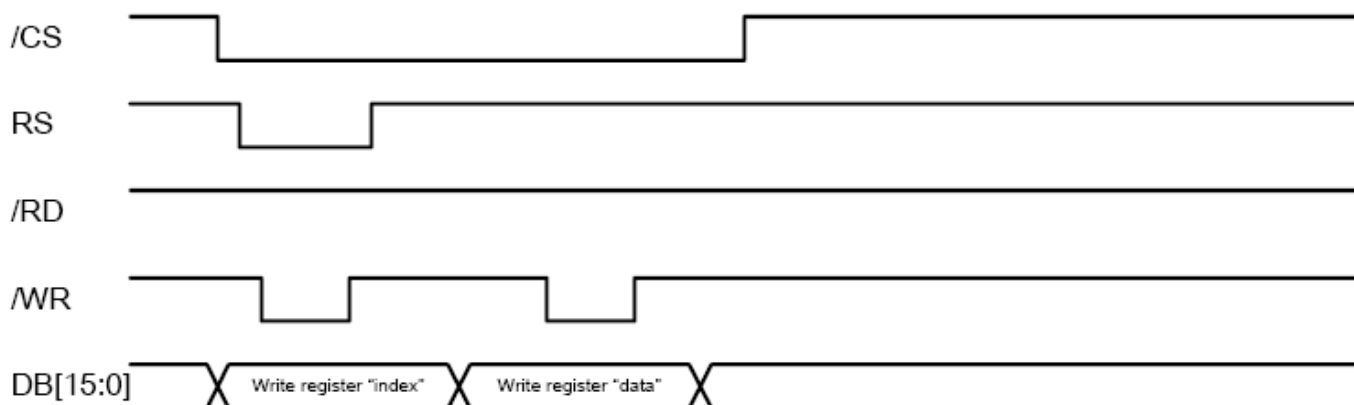
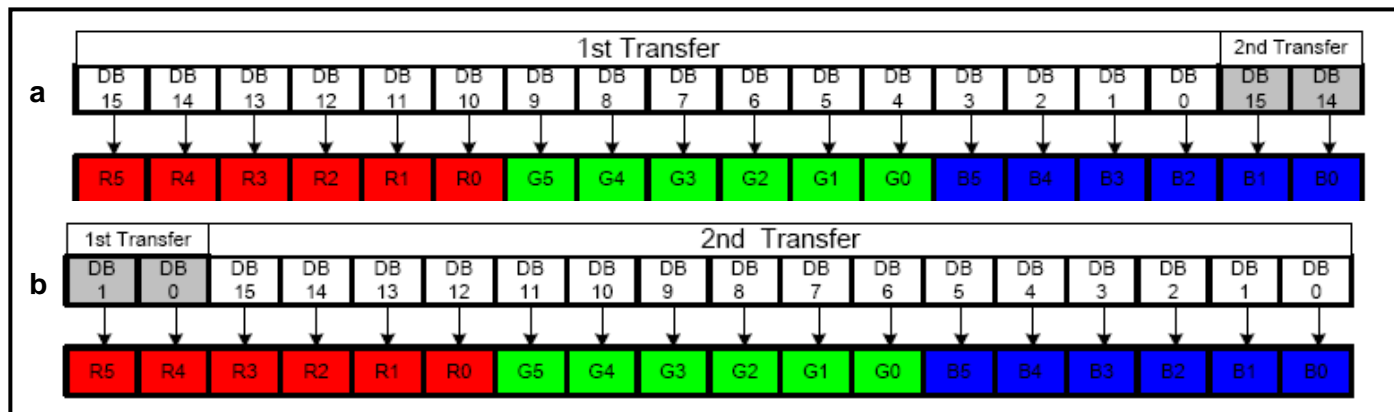

Figure 5.2 i80 16-bit System Bus Interface Timing



5.3 GRAM write timing in i80 series system



a. TRI=1,DFM=0,16+2-bit; b. TRI=1,DFM=1,2+16-bit;

Figure 5.3.1 i80-System Interface with 16-bit Data Bus

GRAM Write Timing

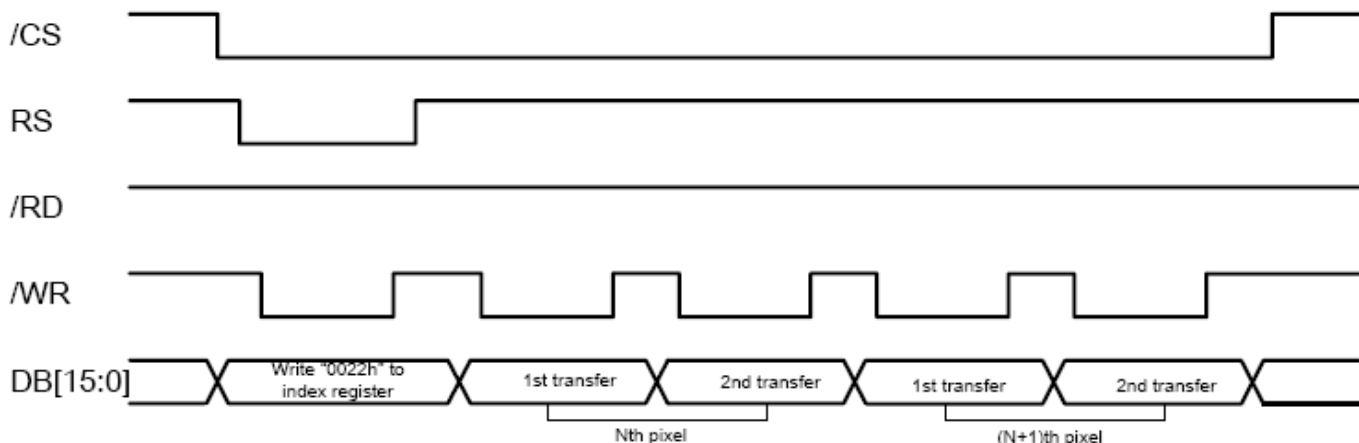
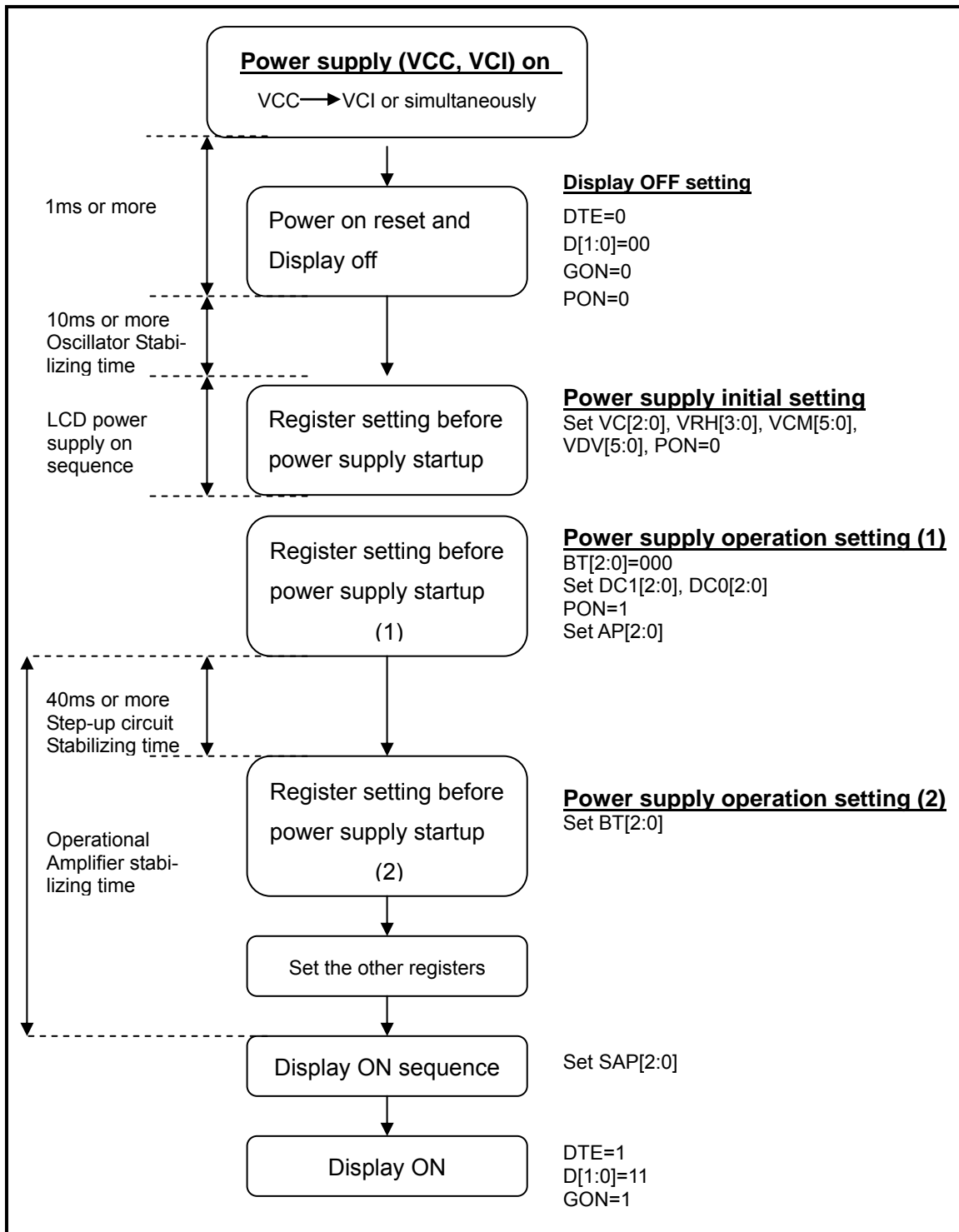

Figure 5.3.2 GRAM Write Timing of i80 16-bit System Interface



6. POWER ON/OFF SEQUENCE

6.1 Power on Sequence





6.2 Power off Sequence

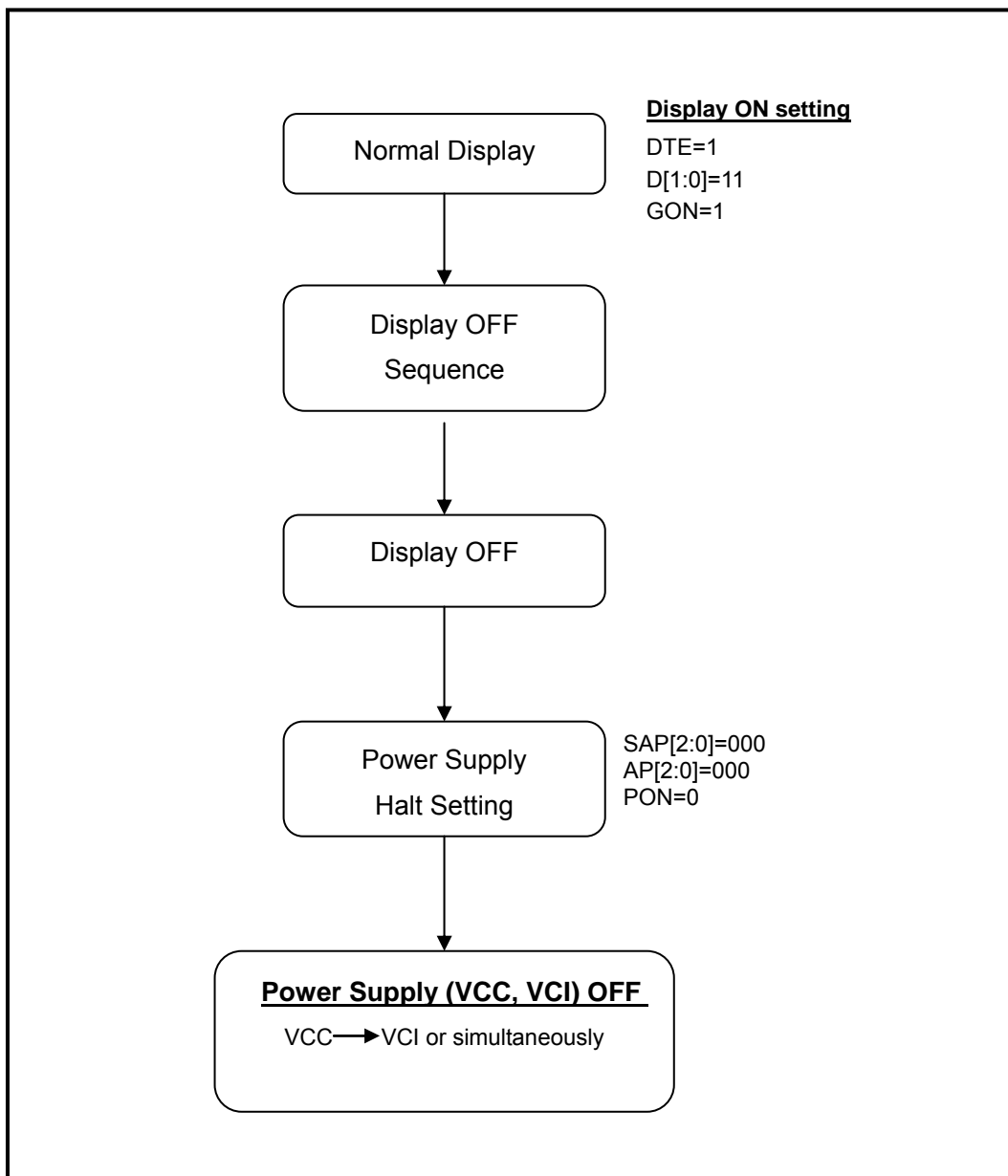



6 OPTICAL CHARACTERISTICS

6.1 Optical Specification

Ta=25°C

Item	Symbol	Condition	Min	Typ.	Max.	Unit	Remark
View Angles	θT	$CR \geq 10$	50	60		Degree	Note 2
	θB		30	40			
	θL		50	60			
	θR		50	60			
Contrast Ratio	CR	$\theta = 0^\circ$		350			Note3
Response Time	Tr	25°C		25		ms	Note4
	Tf						
Chromaticity	White	x	Brightness is on	0.260	0.310	0.360	Note1, 5
		y		0.280	0.330	0.380	
	RED	x		0.564	0.614	0.664	
		y		0.321	0.371	0.421	
	GREEN	x		0.284	0.334	0.384	
		y		0.547	0.597	0.647	
	BLUE	x		0.091	0.141	0.191	
		y		0.060	0.110	0.160	
Uniformity	U		75	80		%	Note6
NTSC				55		%	Note 5
Luminance (with TSP)	L		150	180		cd/m ²	Note7

Test Conditions:

1. Vcc=2.8V $I_L = 20\text{mA}$ (Backlight current), the ambient temperature is 25°C.
2. The test systems refer to Note 1 and Note 2.



Note 1: Definition of optical measurement system.

The optical characteristics should be measured in dark room. After 5 minutes operation, the optical properties are measured at the center point of the LCD screen. All input terminals LCD panel must be ground when measuring the center area of the panel.

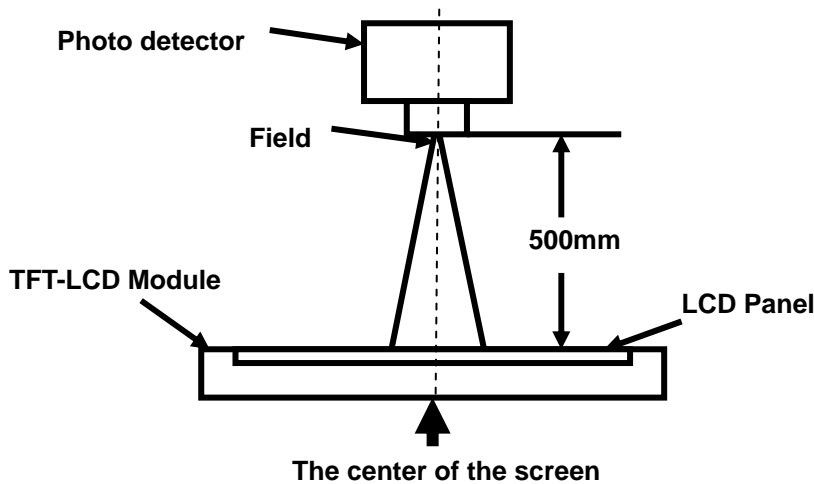

Item	Photo detector	Field
Contrast Ratio	SR-3	1°
Luminance		
Chromaticity		
Lum Uniformity		
Response Time	BM-7A	

Note 2: Definition of viewing angle range and measurement system.

viewing angle is measured at the center point of the LCD by LCD5200.

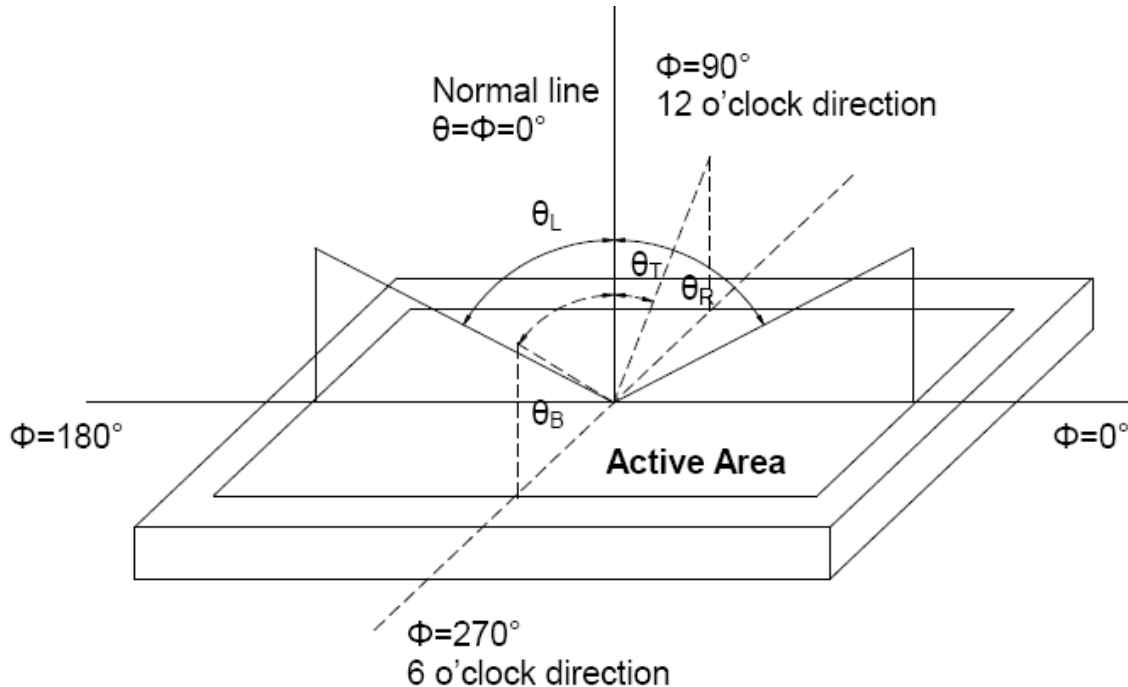

Fig. 1 Definition of viewing angle



Note 3: Definition of contrast ratio

$$\text{Contrast ratio (CR)} = \frac{\text{Luminance measured when LCD is on the "White" state}}{\text{Luminance measured when LCD is on the "Black" state}}$$

“White state “:The state is which the LCD is driven by V_{white} .

“Black state”: The state is which the LCD is driven by V_{black} .

V_{white} : To be determined V_{black} : To be determined.

Note 4: Definition of Response time

The response time is defined as the LCD optical switching time interval between “White” state and “Black” state. Rise time (T_{ON}) is the time between photo detector output intensity changed from 90% to 10%. And fall time (T_{OFF}) is the time between photo detector output intensity changed from 10% to 90%.

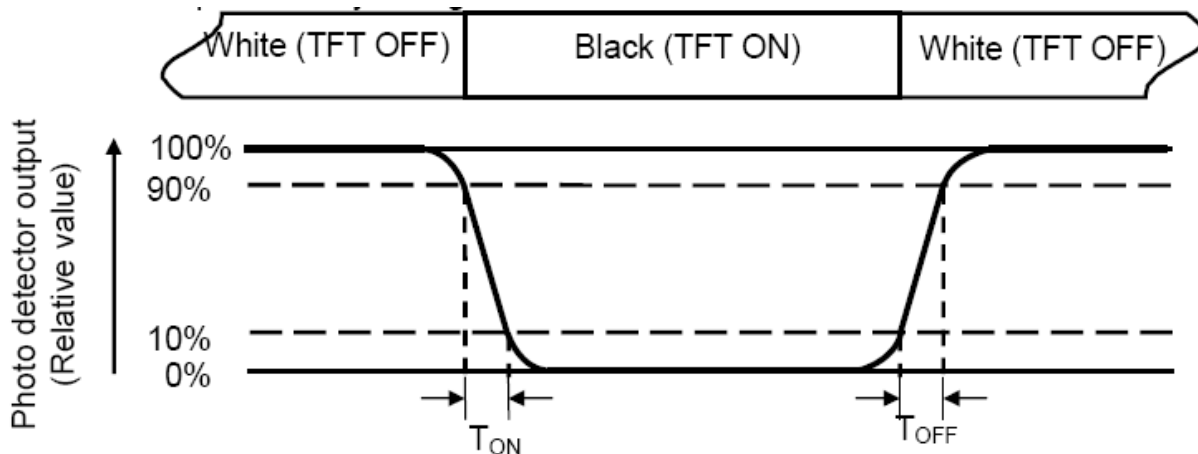

Note 5: Definition of color chromaticity (CIE1931)

Color coordinates measured at center point of LCD.



Note 6: Definition of Luminance Uniformity

Active area is divided into 9 measuring areas (Refer Fig. 2). Every measuring point is placed at the center of each measuring area.

$$\text{Luminance Uniformity}(U) = L_{\min} / L_{\max}$$

L-----Active area length W----- Active area width

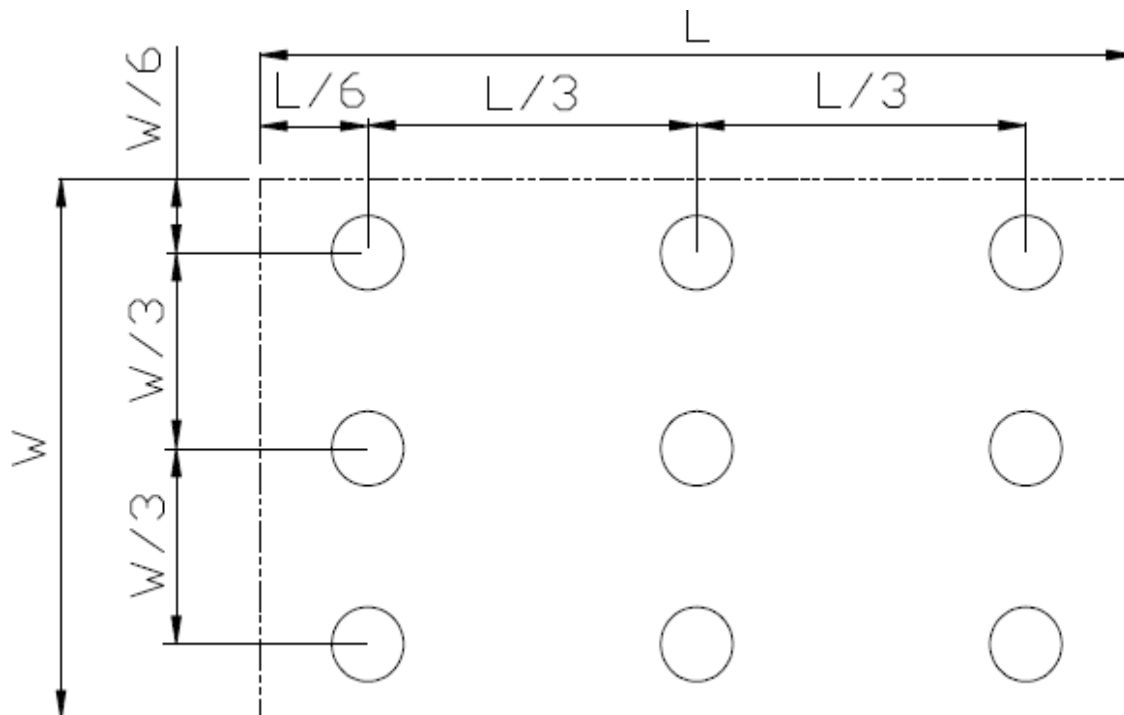

Fig. 2 Definition of uniformity

Lmax: The measured maximum luminance of all measurement position.

Lmin: The measured minimum luminance of all measurement position.

Note 7: Definition of Luminance :

Measure the luminance of white state at center point



7 Environmental / Reliability Tests

No	Test Item	Condition	Remarks
1	High Temperature Operation	Ts=+60°C, 120hrs	Note1 IEC60068-2-2,GB2423.2—89
2	High Temperature & High Humidity storage	+60°C, 90% RH max,120 hours	IEC60068-2-3, GB/T2423.3—2006
3	Low Temperature Operation	Ta=-20°C, 120hrs	Note 2, IEC60068-2-1 GB2423.1—89
4	High Temperature Storage (non-operation)	Ta=+70°C, 120hrs	IEC60068-2-2, GB2423.2—89
5	Low Temperature Storage (non-operation)	Ta=-20°C, 120hrs	IEC60068-2-1 GB2423.1—89
6	Thermal Shock (non-operation)	-20°C 30 min~+60°C 30 min, Change time:5min, 20 Cycle	Start with cold temperature, end with high temperature IEC60068-2-14,GB2423.22—87
7	Electro Static Discharge (operation)	C=150pF, R=330Ω, 5points/panel Air:±8KV, 5times;Contact:±4KV, 5 times; (Environment: 15°C ~35°C, 30%~60%, 86Kpa~106Kpa)	IEC61000-4-2 GB/T17626.2—1998
8	Vibration (non-operation)	Frequency range:10~55Hz, Stroke:1.5mm Sweep:10Hz~55Hz~10Hz 2 hours for each direction of X.Y.Z.(6 hours for total)	IEC60068-2-6 GB/T2423.10—1995
9	Shock (non-operation)	60G 6ms, ±X,±Y,±Z 3times for each di- rection	IEC60068-2-27 GB/T2423.5—1995
10	Package Drop Test	Height:80 cm, 1 corner, 3 edges, 6 surfaces	IEC60068-2-32 GB/2423.8—1995

Note1: Ts is the temperature of panel's surface.

Note2: Ta is the ambient temperature of samples.



8. MECHANICAL DRAWING

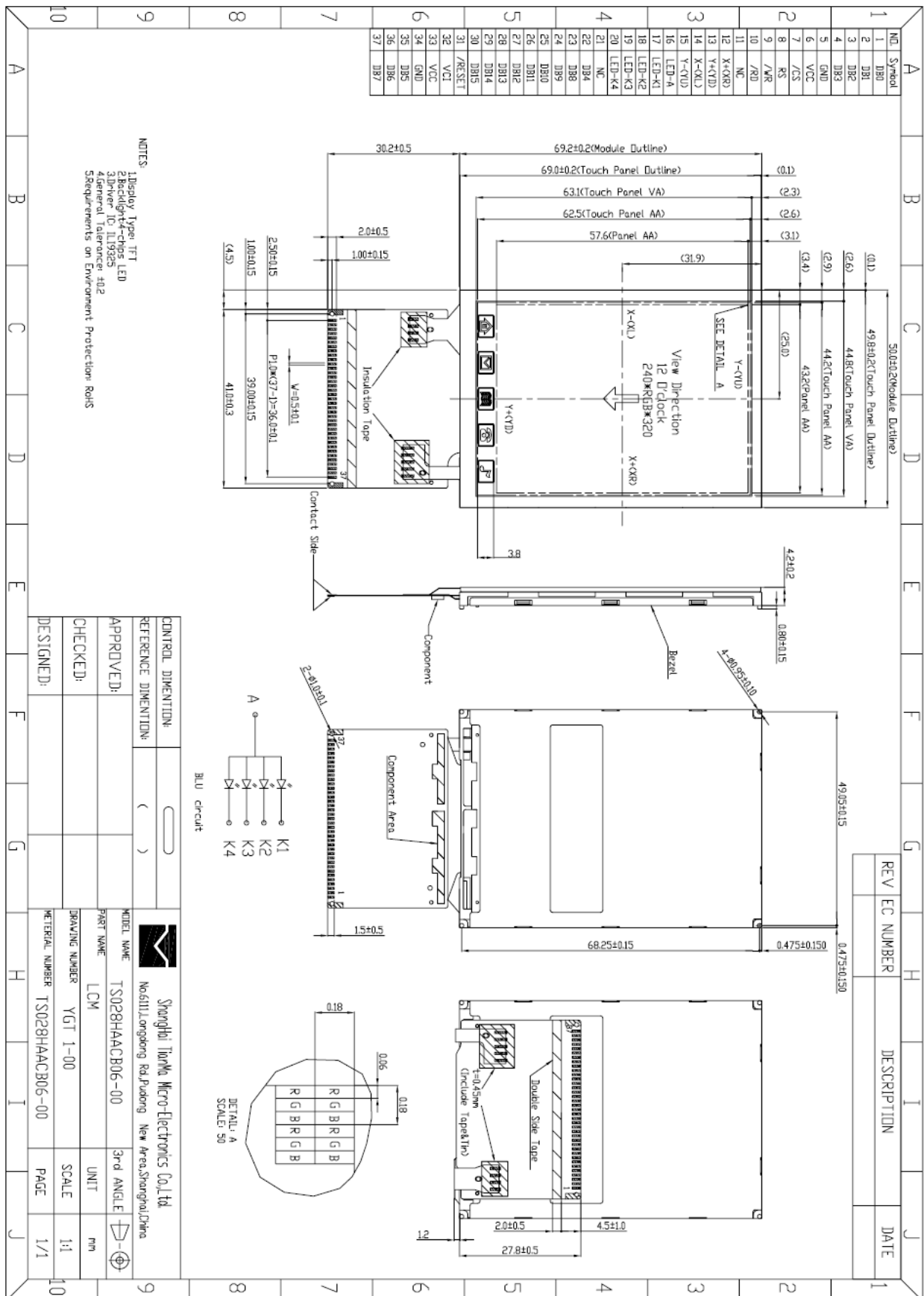



9. Packing Drawing

TBD



10. Precautions for Use of LCD Modules

10.1 Handling Precautions

10.1.1. The display panel is made of glass. Do not subject it to a mechanical shock by dropping it from a high place, etc.

10.1.2. If the display panel is damaged and the liquid crystal substance inside it leaks out, be sure not to get any in your mouth, if the substance comes into contact with your skin or clothes, promptly wash it off using soap and water.

10.1.3. Do not apply excessive force to the display surface or the adjoining areas since this may cause the color tone to vary.

10.1.4. The polarizer covering the display surface of the LCD module is soft and easily scratched. Handle this polarizer carefully.

10.1.5. If the display surface is contaminated, breathe on the surface and gently wipe it with a soft dry cloth. If still not completely clear, moisten cloth with one of the following solvents:

— Isopropyl alcohol

— Ethyl alcohol

Solvents other than those mentioned above may damage the polarizer. Especially, do not use the following:

— Water

— Ketone

— Aromatic solvents

10.1.6. Do not attempt to disassemble the LCD Module.

10.1.7. If the logic circuit power is off, do not apply the input signals.

10.1.8. To prevent destruction of the elements by static electricity, be careful to maintain an optimum work environment.

a. Be sure to ground the body when handling the LCD Modules.

b. Tools required for assembly, such as soldering irons, must be properly ground.

c. To reduce the amount of static electricity generated, do not conduct assembly and other work under dry conditions.

d. The LCD Module is coated with a film to protect the display surface. Be care when peeling off this protective film since static electricity may be generated.

10.2 Storage precautions

10.2.1. When storing the LCD modules, avoid exposure to direct sunlight or to the light of fluorescent lamps.

10.2.2. The LCD modules should be stored under the storage temperature range. If the LCD modules will be stored for a long time, the recommend condition is:

Temperature : 0°C ~ 40°C Relatively humidity: ≤80%

10.2.3. The LCD modules should be stored in the room without acid, alkali and harmful gas.

The information contained herein is the exclusive property of SHANGHAI TIANMA MICRO-ELECTRONICS Corporation, and shall not be distributed, reproduced, or disclosed in whole or in part without prior written permission of SHANGHAI TIANMA MICRO-ELECTRONICS Corporation.



10.3 Transportation Precautions

The LCD modules should be no falling and violent shocking during transportation, and also should avoid excessive press, water, damp and sunshine.